

exalux

BRIGHT INNOVATIONS, BEYOND LIGHTING



CINEMA & BROADCASTING SOLUTIONS

2 019 / Q1



LIGHT



DIMMING



CONNECT



CONTROL

ABOUT EXALUX

Here at EXALUX™, innovation is at the heart of our strategy. We stand out for our ability to anticipate trends and establish links between needs and technology.

We specialise in designing distinctive lighting, lighting-control solutions and technologies for the entertainment industry.

EXALUX™ has developed its business based on values that have helped make our products a success.

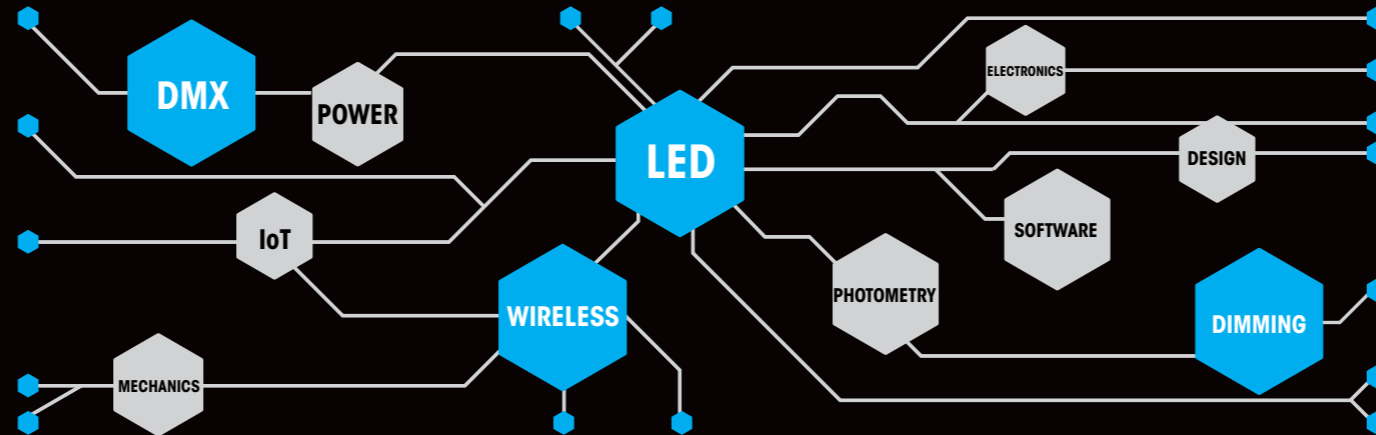

INNOVATION & TECHNOLOGY, WITH PASSION

The way we develop our products is by aiming to exceed expectations, with a focus on user-friendliness, design and performance.

Our philosophy is founded on the scalability of solutions and the ability to adapt to both customer needs and environmental constraints.

All our products are engineered and made in France with passion.



4

CONNECT

EXALUX™ CONNECT Wireless solutions replace your DMX cables by a wireless link. We bring you turnkey solutions that are based on Wi-Fi or CRMX by LumenRadio™ Technologies.

EXALUX™ offers the widest range of wireless DMX solutions on the market.

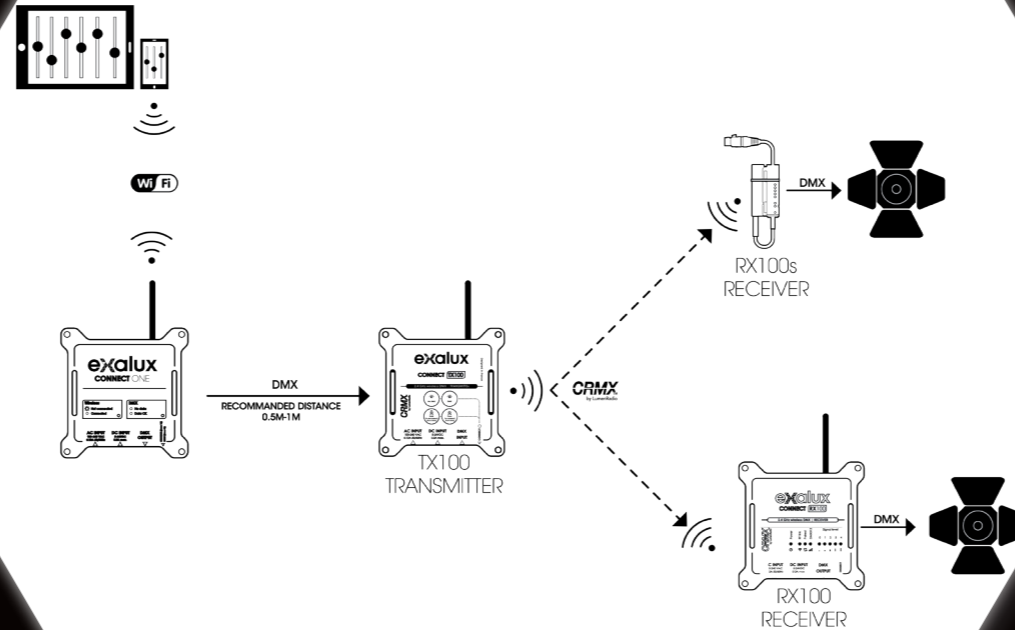

5

FULLY WIRELESS, TOTAL FREEDOM

EXALUX™ CONNECT are “user centric” solutions designed to make you save time and stress.

Thanks to EXALUX™ CONNECT solutions, remotely control your DMX devices with your tablet or smartphone has never been easier.

CONNECT ONE

EXALUX™ CONNECT-ONE is an «All-In-One» gateway which creates its own Wi-Fi network and allows you to control any DMX device with a tablet or a smartphone.

CONNECT-ONE has already its own Wi-Fi and Art-Net/DMX interfaces so it works without the need for an extra access point or extra Art-Net Node.

CONNECT-ONE is fully compatible with LUMINAIR App.

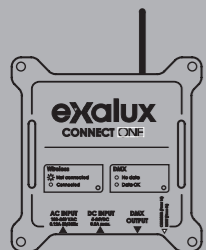

- 2.4GHz 802.11g Wi-Fi Access point
- Embedded Art-Net-DMX Node
- 1 DMX Universe
- Wi-Fi channel selector
- 50-100m range
- XLR 5PTS DMX output
- 5-24VDC / 110-220VAC Input



CONNECT TX100

CONNECT TX100 is a wireless DMX transmitter that allows you to control any DMX device with a DMX console.

Based on LumenRadio™ CRMX technology, EXALUX™ TX100 brings DMX fidelity with a long range and without any latency.

You can link an infinite number of CRMX receivers to the TX100 transmitter.



- 2.4GHz CRMX transmitter
- CRMX by LumenRadio
- 1 DMX Universe
- 500-1000m range
- XLR 5PTS DMX input
- 5-24VDC / 110-220VAC Input



CONNECT RX100

CONNECT RX100 is a wireless DMX receiver that allows you to control any DMX device with a DMX console.

Based on LumenRadio™ CRMX technology, EXALUX™ CONNECT RX100 brings DMX fidelity with a long range and without any latency. You can link an infinite number of RX100 receivers to the TX100 transmitter.

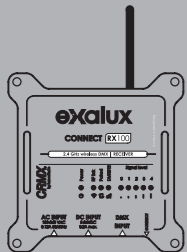

- 2.4GHz CRMX receiver
- CRMX by LumenRadio
- 1 DMX Universe
- 500-1000m range
- XLR 5PTS DMX output
- 5-24VDC / 110-220VAC Input



CONNECT RX100s

CONNECT RX100s is a standalone wireless DMX receiver especially designed to be powered from the USB connectors of a LED panel. RX100s can also run up to 10 hours with the small EXALUX™ PowerBank battery.

RX100s suits with any LED fixture thanks to the flexible «connector on cable» system.

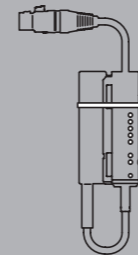

- 2.4GHz CRMX receiver
- CRMX by LumenRadio
- 1 DMX Universe
- 50-100m range
- XLR 5PTS DMX output
- 5VDC USB Input



10

CONTROL

EXALUX™ CONTROL solutions allow you to remotely control DMX devices in a simple and efficient way.

We bring you reliable solutions that are based on CRMX by LumenRadio™ Technologies.

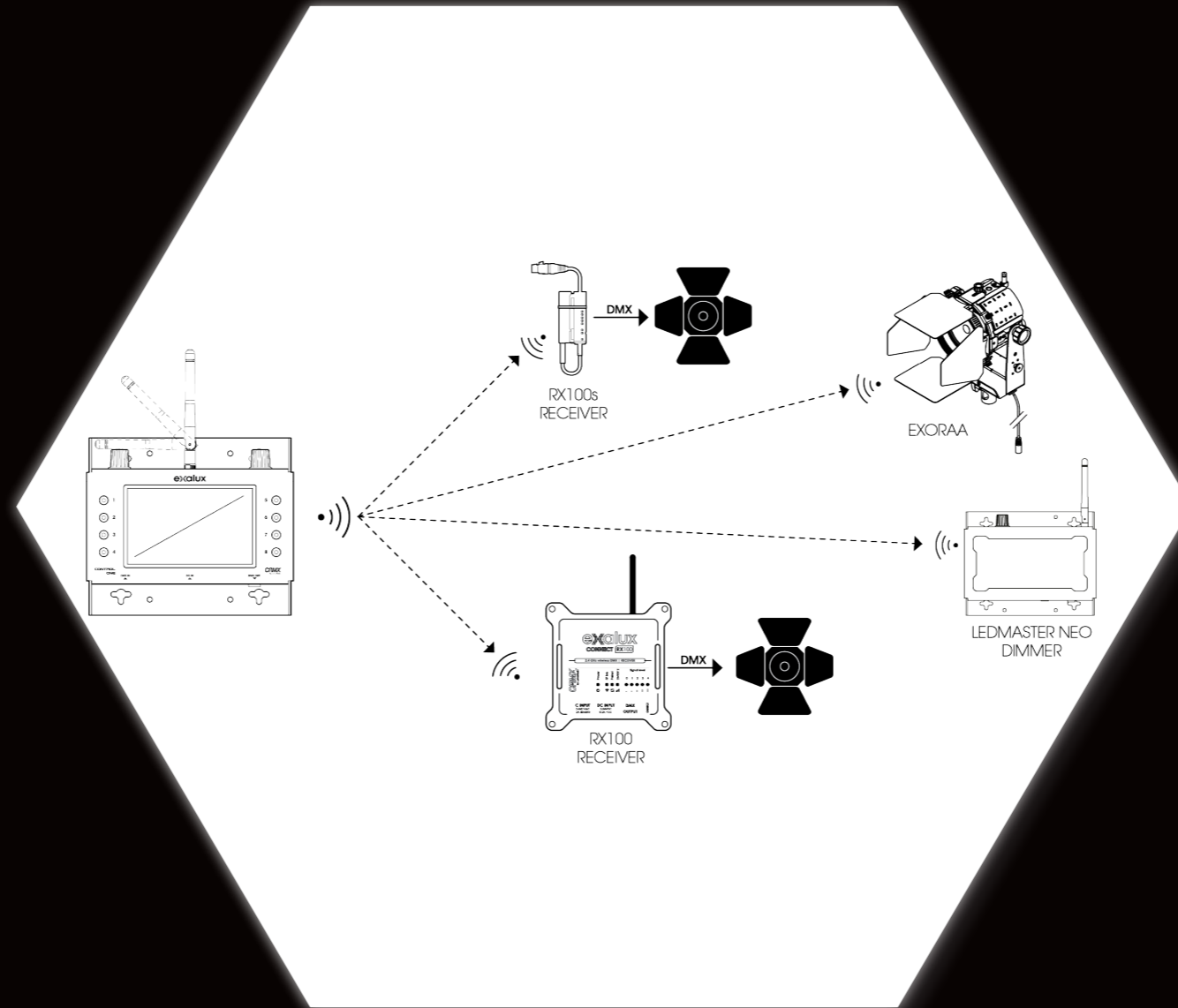

11

TACTILE, WIRELESS, USER FRIENDLY

EXALUX™ CONTROL are “user centric” products designed to make you save time and stress.

Thanks to the touch apacitiv technology, remotely control your DMX devices has never been easier.

CONTROL ONE

EXALUX™ CONTROL ONE is an all-in-one wireless DMX controller especially designed to control lights with sense and simplicity. EXALUX™ CONTROL ONE is your ideal companion to control your DMX devices on cinema sets. It is also perfect for small TV studio setups.

EXALUX™ CONTROL ONE offers up to 4 DMX applications in a single box : Fader | Dimmer | Recorder | Player.

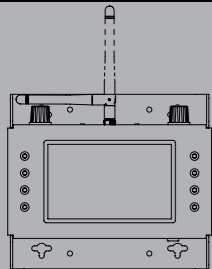

- 2.4GHz CRMX By LumenRadio
- TFT 5.0" capacitiv Touch display
- 1 DMX Universe
- USB 5VDC / XLR 4 10-24VDC Input

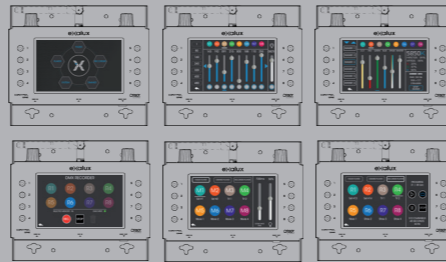

CONTROL SKY

EXALUX™ CONTROL SKY is an all-in-one wireless DMX controller. The controller has a dedicated application that allows to control the ARRI™ SkyPanel™ LED panel when Ultimate P30 mode (firmware 4.0) is selected. CONTROL SKY is also able to control all your DMX devices.

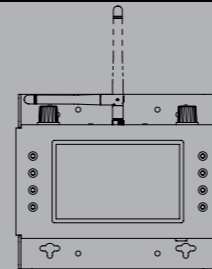

- 2.4GHz CRMX By LumenRadio
- TFT 5.0" capacitiv Touch display
- 1 DMX Universe
- USB 5VDC / XLR 4 10-24VDC Input

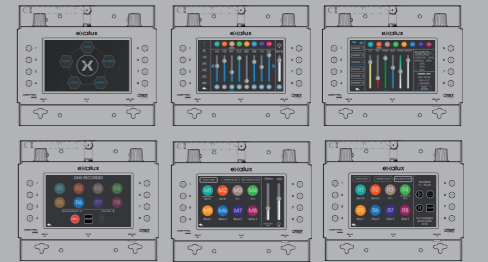

CONTROL DISCOVERY

EXALUX™ CONTROL DISCOVERY is designed to be mounted to a standard light switch flush/mounting box or directly onto the wall, which enables quick and easy installation. It is a perfect controller for small TV studio setups.

EXALUX™ CONTROL DISCOVERY offers up to 512 DMX faders and 3 memories in a small display. A pin code can be set to prevent accidental changes of settings. This controller can be customized and required a dedicated dimmer/interface to be used.

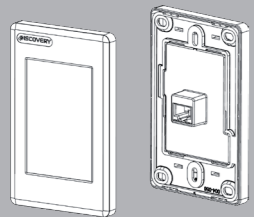

- Wall Mount «Pseudo» DMX controller
- TFT 3.5" Resistive Touch display
- 1 DMX Universe
- RJ45 DC In (5-36V) and data in/out



DMX CONNECT+

EXALUX™ DMX CONNECT + is a virtual console that works with all Art-Net / DMX Wireless interfaces such as EXALUX™ CONNECT ONE.

DMX Connect + works the exact same way than your hardware DMX controller you used for years. Every fader is linked to a DMX address. Easy and friendly to use!



- 512 channels
- 16 memories
- 1 DMX Universe
- Project manager / sharing

- Mode console / Memories
- Settings lockble with a password
- Compatible with all Art-Net / DMX devices
- Ready to work with CONNECT ONE

16

DIMMING

EXALUX™ DIMMING solutions are based on a powerful technology that combines hardware and software and allows soft, smoother and accurate dimming.

You can shoot films in slow motion without any risk of flickering, even at very low dimming level, between 0 and 10 %.

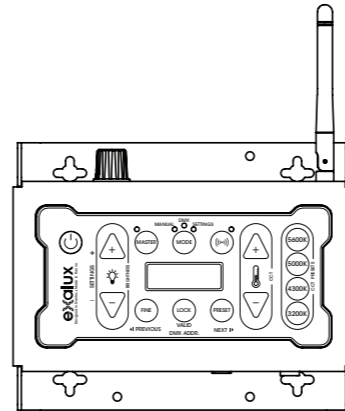
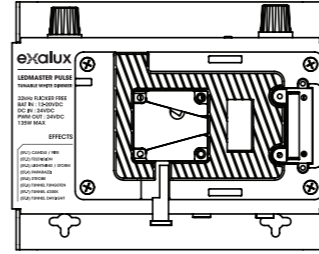
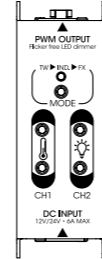
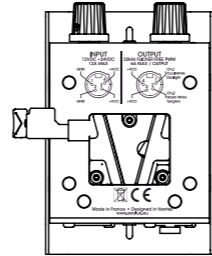

17

FULLY FLICKER FREE, OPTIMISED FOR LED

EXALUX™ dimmers are optimised for LED technology so you can dim down without colour shifting.

Get the right CCT, whatever the LED ribbon thanks to the patented CCT synthesizer.

LEDMASTER™ CLASSIC

EXALUX™ LEDMASTER™ CLASSIC is a bi-colour constant voltage LED dimmer. It allows to adjust the CCT from tungsten to daylight and brightness from 0% to 100% with incredible precision.

LEDMASTER™ CLASSIC is basic but easy to use with any constant voltage bi-colour LED ribbons with a perfect accuracy.

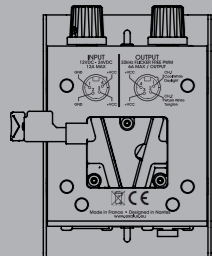

- 12-24V Constant voltage
- Tunable White / Dual channel mode
- 6A + 6A output capability
- XLR 4, 12-24VDC Input / output
- 32kHz Flicker Free PWM
- Belt clip + Vlock mechanism
- Analog controls
- Robust aluminium enclosure

LEDMASTER™ STICK

EXALUX™ LEDMASTER™ STICK is cost effective bi-colour constant voltage LED dimmer. It allows to adjust the CCT from tungsten to daylight and brightness from 0% to 100%.

LEDMASTER™ STICK is extremely compact. It has been specifically designed to provide a powerful and efficient dimming solution at a very attractive price.

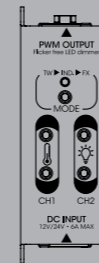

- 12 - 24V Constant voltage
- Tunable White / Dual channel mode
- 3A + 3A output capability
- XLR 4, 12-24VDC Input / output
- 32kHz Flicker Free PWM
- 1 preset
- Digital controls
- Robust aluminium enclosure

LEDMASTER™ PULSE

EXALUX™ LEDMASTER™ PULSE is a high performance dimmer that combines in one box, a multi range CCT synthesizer, a DMX decoder and a high efficiency step up DC converter.

LEDMASTER™ PULSE offers 4 CCT ranges adjustments and is therefore compatible with a wide variety of LED fixtures such as EXALUX™ LEDZEP™, PILLOW™ and many others.

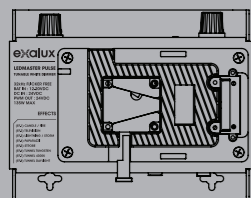

- 24V Constant voltage dimmer
- Tunable White / FX mode
- 4,5A + 4,5A output capability
- VLOCK / XLR 4 DC Input
- CCT Preset / CCT range set up
- DMX 512 (XLR5 Input)
- 108W Step Up DC converter
- Robust aluminium enclosure

LEDMASTER™ NEO

EXALUX™ LEDMASTER™ NEO is a universal constant voltage LED dimmer specifically designed to dim any constant voltage bi-colour LED systems from 2000K to 7000K.

Thanks to its high output capacity (10A+10A), LEDMASTER™ NEO will allow you to dim up to 580W of LED light (@24VDC). LEDMASTER™ NEO is really ideal for dimming large areas of LED light.

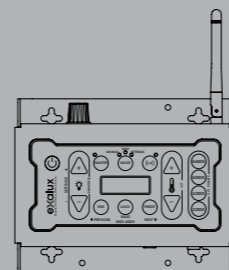

- 12 - 24V Constant voltage
- Tunable White / Dual channel mode
- 10A + 10A output capability
- XLR 4, 12-24VDC Input / output
- CCT Preset / Patented CCT synthesizer
- DMX 512 (XLR5 Input) / Wireless CRMX
- Rugged control panel with LED display
- Robust aluminium enclosure

LEDMASTER™ STUDIO.M

EXALUX™ LEDMASTER™ STUDIO has been designed to create bright decorations in studios and TV sets with LED ribbons. The "master-slave" concept simplifies wiring and reduces installation costs because a single master dimmer can drive a multitude of slave dimmers.

LEDMASTER™ STUDIO embeds a 8/16 bits DMX interface and a 4 specific dimming modes which allow you to switch between RGBW, RGBW+Master, Tunable White and Separate Channel dimming.

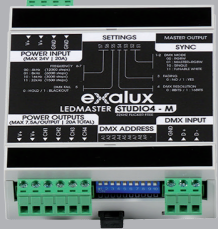

- 12 - 24V Constant voltage dimmer
- RGB, RGBW, Tunable White, Separate
- 4x 7.5A (20A max) output capability
- 8 / 16 bits mode
- PWM frequency from 4kHz to 32 kHz
- DMX 512 input
- Pluggable Terminal blocks
- RJ45 Sync output to slave dimmer

LEDMASTER™ STUDIO.S

Thanks to the "Sync" connection, it is possible to easily and cheaply increase the number of PWM outputs and thus the number of LED ribbons to drive by linking a Slave to the Master.

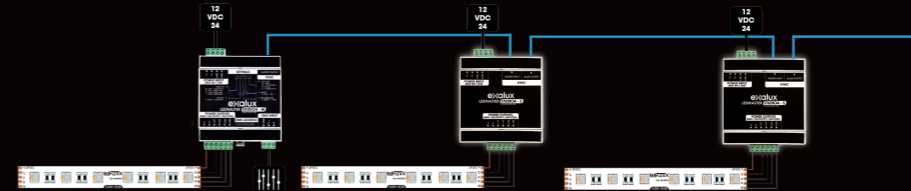

- 12 - 24V Constant voltage dimmer
- RJ45 Sync output to master dimmer
- 4x 7.5A (20A max) output capability
- Pluggable Terminal blocks

DIMLITE™ DL2X2A

EXALUX™ DIMLITE DL2X2A is a mini OEM dimmer for bi-colour LED sources. It has been designed to be discreetly integrated into film sets with a high quality dimming at a very attractive price.

The dimmer integrates the best of the EXALUX™ technology, including the high frequency PWM driver which allows a smooth and completely «Flicker Free» dimming.

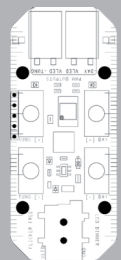

- 12 - 24V Constant voltage dimmer
- Separate channel
- 2A + 2A output capability
- DC JACK 2.1MM, 12-24VDC In/out
- 32 kHz PWM frequency
- 1 024 levels per channel
- Poke-In Terminal connectors
- Lightweight (10g)

DIMLITE™ USB+STIXX

EXALUX™ DIMLITE USB is a mini dimmer designed for STIXX LED sources. DIMLITE USB has been designed to be discreetly integrated into clothing or places where space is tight.

DIMLITE USB is delivered in kit with two light sticks.

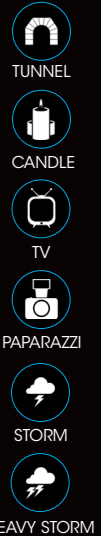

- 24V Constant voltage dimmer
- Tunable White + FX modes
- 0,2A + 0,2A output capability
- PWM low side switching
- STIXX L : 260x29x26mm | 3W
- STIXX S : 150x29x26mm | 1,6W
- 2200K > 6500K
- CRI : 95 typ

DIMLITE™ ROCK

EXALUX™ DIMLITE™ ROCK is a OEM dimmer for bi-colour LED sources especially designed to be easily integrated on the panel of an enclosure.

You set the tungsten and daylight CCTs, the brightness difference in between the two CCTs then the synthesizer will reproduce the CCT of your choice which will be indicated on the screen.



- 12 - 24V Constant voltage dimmer
- Tunable White
- 4x 3A (12A max) output capability
- Master / Slave mode
- Patented CCT synthesizer / 4 Preset
- DMX 512 Input / output
- Bluetooth 4.0
- Rugged control panel with LED

UBOOST™ VLOCK

EXALUX™ uBOOST™ VLOCK step up and regulate at a fixed DC24V the voltage from an V-LOCK battery. This converter is the essential tool to power any fixture in an easy and safe way.

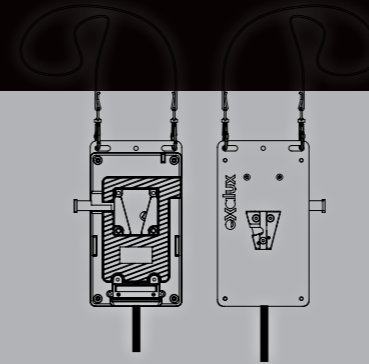

- 24VDC step up converter
- Input voltage : 12-20VDC
- 120W max
- VLOCK socket
- Efficiency : up to 98%
- Switching frequency : 1MHz
- XLR4 output
- 6,3A internal fuse

28

LIGHTING

EXALUX™ designs and manufactures its fixtures with high quality components and LEDs.

Our lighting fixtures are known for their design, their colour temperature accuracy, their high colour rendering index and their high efficiency.

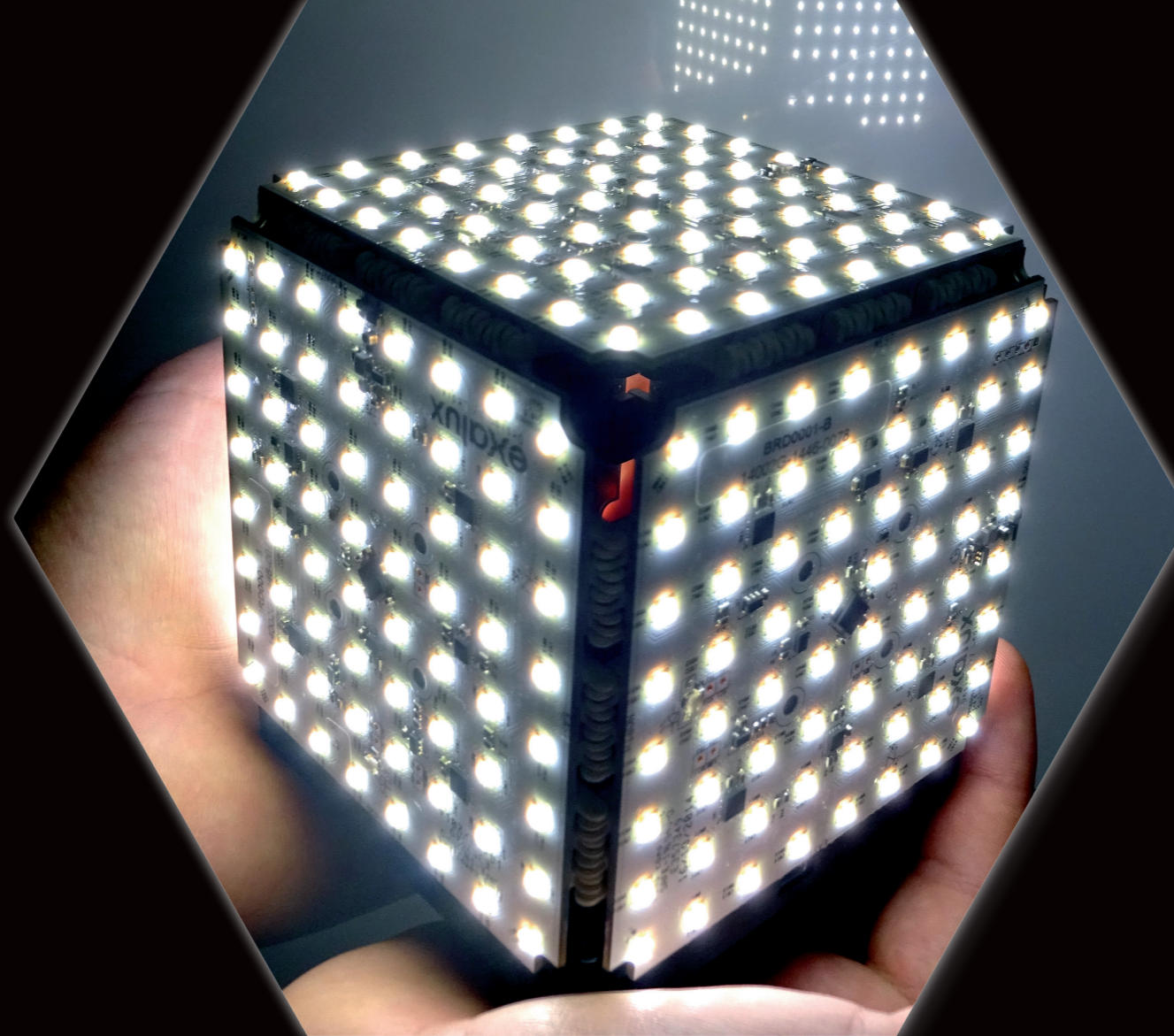

29

BEAUTIFUL LIGHT, HIGH EFFICIENCY

EXALUX™ carefully inspects LED and colour temperature specifications to deliver great colour rendering that is appropriate for cinema and broadcasting markets.

ROCK CLASSIC

EXALUX™ ROCK LED panels are rainproof (IP54). ROCK CLASSIC fixture only draws 60W of power and delivers 4000 lumen

Thanks to the innovative LuxiFY™ LED Engine ROCK LED panels produce of beautiful soft light with a great colour rendering.

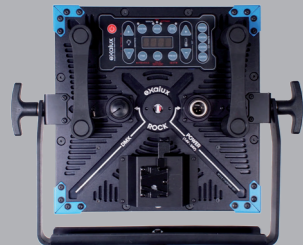
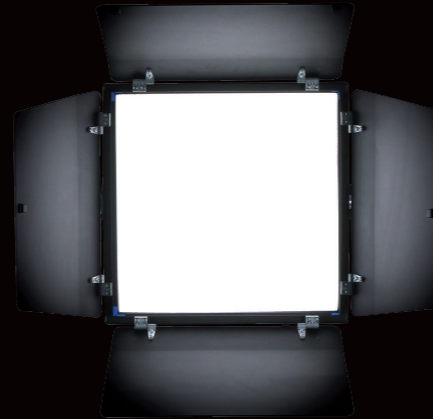

- 4 000 lumen output
- Tunable White 2700K - 6500K
- CRI : 95 (typ) | TLCI : 98
- 60W power consumption
- DMX 512 Input
- Bluetooth 4.0
- High efficiency (up to 81lm/w)
- IP 54 rainproof

ROCK WIDE

ROCK WIDE fixture only draws 118W of power and delivers 8300 lumen.

EXALUX™ ROCK panels are finely tunable (down to 0,1%) and deliver a constant flux whatever the correlated colour temperature. Moreover, the CCT remains stable even at very low level.

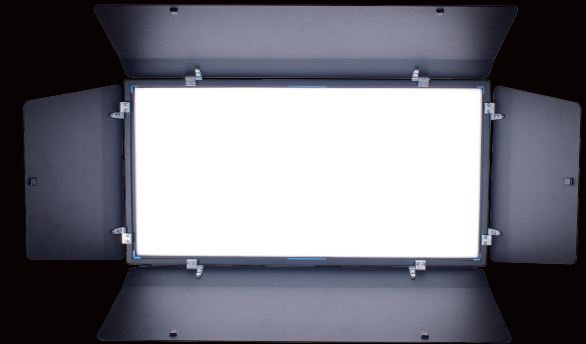

- 8 300 lumen output
- Tunable White 2700K - 6500K
- CRI : 95 (typ) | TLCI : 98
- 118W power consumption
- DMX 512 Input / output
- Bluetooth 4.0
- High efficiency (up to 81lm/w)
- IP 54 rainproof

EXORAA TRACK

EXALUX™ EXORAA™ is an ultra compact LED fixture designed for small TV studios, radios and Web TV where space is tight.

EXORAA™ concept is based on a SORAA™ AR111 LED engine and fully customizable with magnetics CCT shifters and lenses.

EXORAA™ TRACK is directly powered through a 3-circuit lighting track.

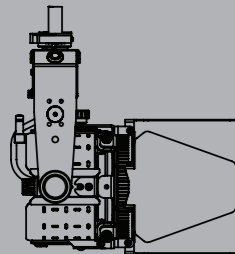

DMX

- 1 040 lm | 4 000K | 9°
- DMX input & output
- 3-circuit lighting track adapter
- 100-240VAC input

CRMX by LumenRadio

- 1 040 lm | 4 000K | 9°
- DMX input & output + CRMX
- 3-circuit lighting track adapter
- 100-240VAC input

EXORAA RAG

Because of its lightness, EXORAA™ RAG is a "Run And Gun" fixture that suits for interviews and productions on the go.

EXORAA™ concept is based on a SORAA™ AR111 LED engine and fully customizable with magnetics CCT shifters and lenses. EXORAA™ RAG is powered by 12VDC PSU or a battery through a DC-Jack connector. The fixture can run up to one hour and a half with a 30Wh small BPU battery.

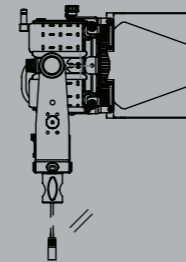

DMX

- 1 040 lm | 4 000K | 9°
- DMX input & output
- 3/8" UNC adapter
- 10-20V DC Jack input

CRMX by LumenRadio

- 1 040 lm | 4 000K | 9°
- DMX input & output + CRMX
- 3/8" UNC adapter
- 10-20V DC Jack input

LEDZEP

EXALUX™ LEDZEP™ is a high-end LED light fixture designed to be robust, easy to use and powerful on the field. LEDZEP™ is built with lightweight and rugged materials to make the fixture light and easy to handle.

LEDZEP™ offers a wide colour temperature range, between 2200K and 6500K. When used with the LEDMASTER PULSE in FX mode, it is possible to simply create very realistic "chimney fire" or "storm" effects.

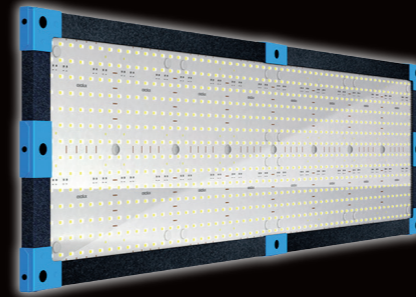
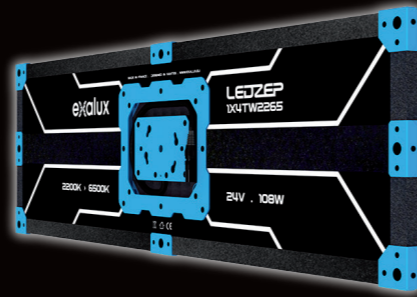

LEDZEP™ LED engine provides high efficiency (up to 96lm/w @6500K). This architecture makes it possible to produce much more light while consuming much less energy. Furthermore, the high density of LEDs reduces the distance between the diffuser and the light source so that LEDZEP™ remains very thin.

LEDZEP™ is easily accessorisable with many light shapers such as Snapbox™ by DopChoice™. Our new ZEPELIN™ inflatable diffuser will produce an ultra soft and glowing light that adds a magic touch to skin tones.

LEDZEP RANGE

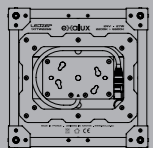

1X1
27W
1754LM

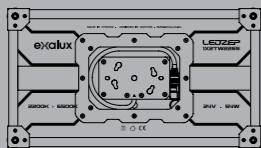

1X2
52W
3509LM

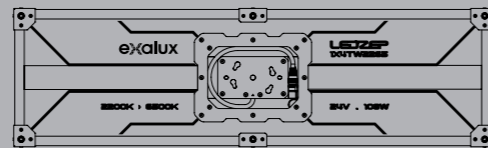

1X4
105W
7019LM

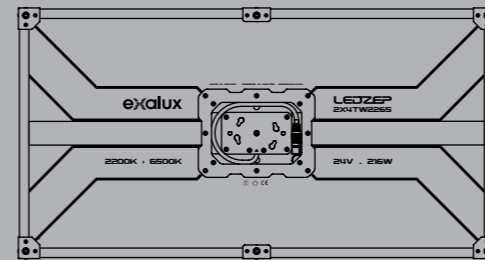

2X4
250W
14 038LM

COMMON FEATURES

- Tunable White 2200K - 6500K
- CRI : 97 (typ)
- 24VDC Input (XLR4)
- Thickness: 19mm

DIMMERS

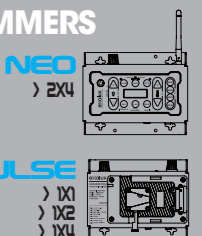

PILLOWLITE

EXALUX™ PILLOW™ is an inflatable lighting fixture created by Olivier Neveu and light powered by EXALUX™. PILLOW™ has been designed to be used very close to the subject, especially to light up skins.

PILLOW™ fixture produces a soft and glowing light that is sure to meet even the highest standards of DOPs when it comes to production lighting. PILLOW™ adds a magic touch to skin tones with a one-of-a-kind diffusion concept.



PILLOW™ is inflatable, which makes it undoubtedly the lightest lighting system available.

PILLOW™ can be held at arm's length for hours without causing fatigue.



- 9 10 lux@1m
- 2 200K - 5 600K
- CRI : 97 (typ)
- Fully dimmable
- 65W max
- 24VDC XLR 4 input
- 960 x 600 x 240mm
- 2,2Kg

COMPATIBLE DIMMERS

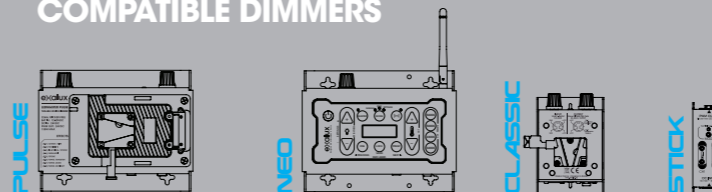

38

LED CREATIVE

EXALUX™ LED CREATIVE is a flexible solution designed to simplify the creation of luminaires for any application.

Find all the LED expertise of EXALUX in a full range of high CRI LED ribbon and modules.

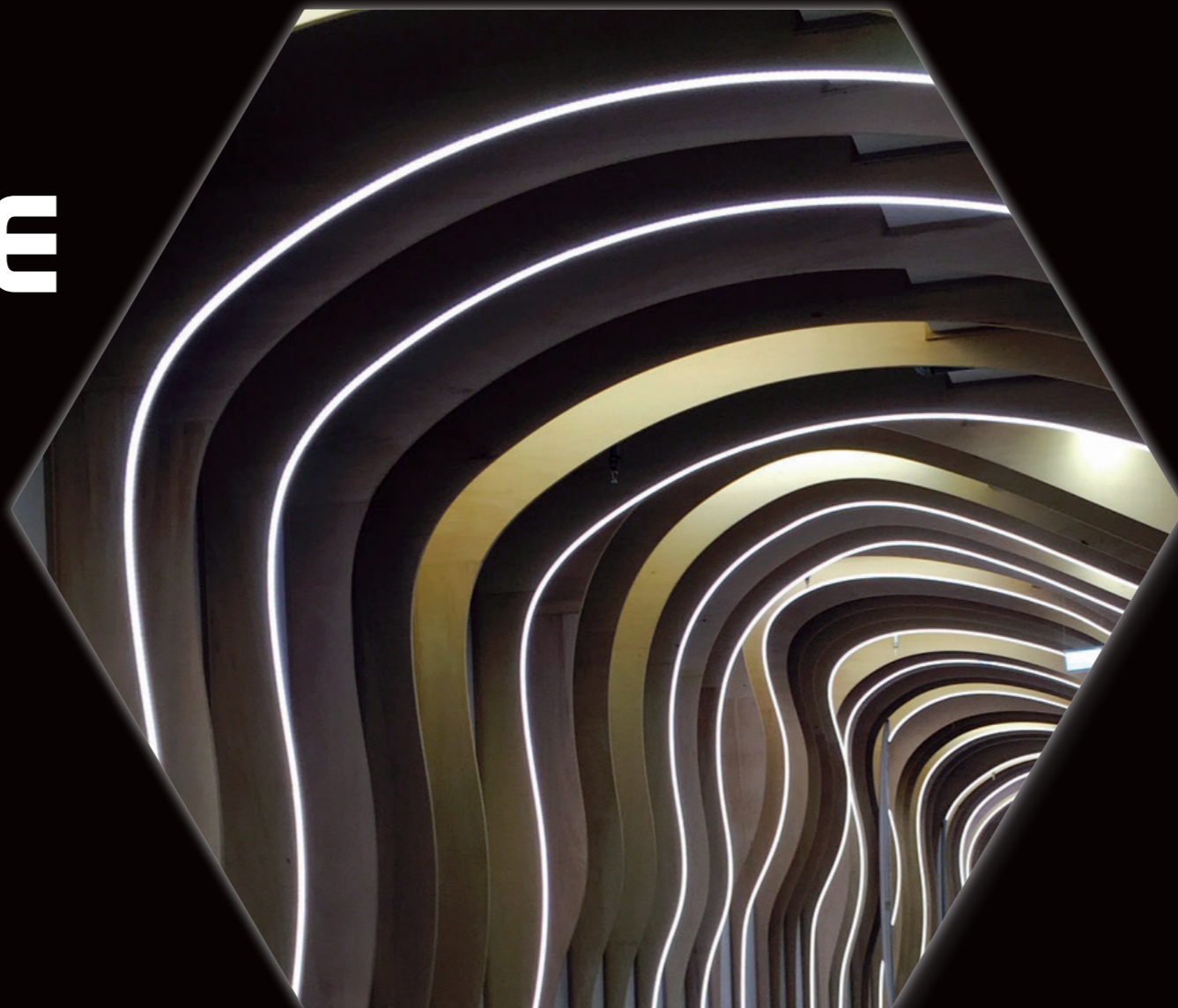

39

TURNKEY SOLUTIONS, BRIGHT CREATIVITY

LED CREATIVE is certainly the easiest way to create custom lighting luminaires.

LED CREATIVE is a clever and versatile lighting solution that will bring you a unequalled freedom to create a world of light !

LED FLEXX COLOUR

LED FLEXX™ COLOUR are all-in-one full colour LED ribbons that can create a colorful light with an incredible richness of colour.

TAPE20-RGB-TW2265 allows you to create a saturated colour light as well as a pastel shade soft light with a powerful white thanks to the 2835 emitters.



TAPE20
RGB-TW2265

- 2 200K + 6 500K + RGB
- CRI : 95 (typ)
- 2 280 lm/m
- 32,5 W/m
- 24VDC

FLX.000.014



TAPE12
RGB-K32

- 3 200K + RGB
- CRI : 95 (typ)
- 900 lm/m
- 16 W/m
- 24VDC

FLX.000.011



TAPE12
RGB-K56

- 5 600K + RGB
- CRI : 95 (typ)
- 968 lm/m
- 18 W/m
- 24VDC

FLX.000.012

LED FLEXX WHITE

LED FLEXX™ WHITE are high CRI LED ribbons designed to meet the requirements in the film and broadcasting industries.

TAPE12-TW2765UHD allows to create a continuous line of light thanks to the high density of the emitters.



TAPE10
TW2265HD

- 2 700K + 6 500K
- CRI : 95 (typ)
- 1 740 lm/m
- 11 W/m
- 24VDC

FLX.000.004



TAPE12
TW2765UHD

- 2 700K + 6 500K
- CRI : 95 (typ)
- 2014 lm/m
- 20 W/m
- 24VDC

FLX.000.015

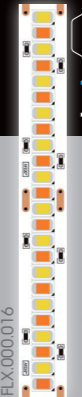

TAPE12
TW2765HP

- 2 700K + 6 500K
- CRI : 95 (typ)
- 2 875 lm/m
- 58 W/m
- 24VDC

FLX.000.016

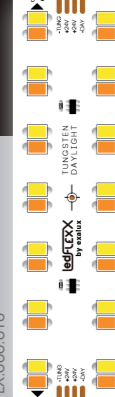

TAPE30
TW2765UHP

- 2 700K + 6 500K
- CRI : 95 (typ)
- 9 500 lm/m
- 112 W/m
- 24VDC

FLX.000.018

LEDMATRIX WHITE

LEDMATRIX™ WHITE are flexible LED sheets designed to be cut into smaller pieces.

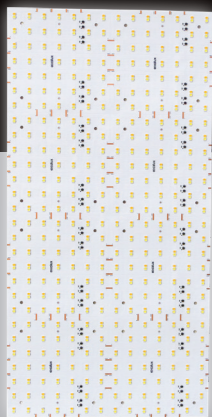

LEDMATRIX 2X4-TW2265

- 2 200K + 6 500K
- CRI : 95 (typ)
- 2x4 modules (170x170mm)
- 6 951 lm
- 90 W / 24VDC

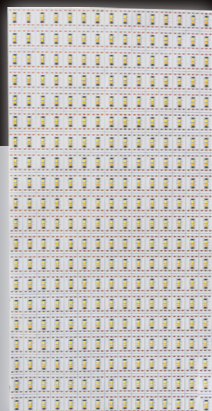

LEDMATRIX 15X20-TW2765

- 2 700K + 6 500K
- CRI : 95 (typ)
- 15x20 modules (24x16mm)
- 13 500 lm
- 225 W / 24VDC

LEDFLEXX DEMO

Find all the expertise of EXALUX in our LED Creative demo board.

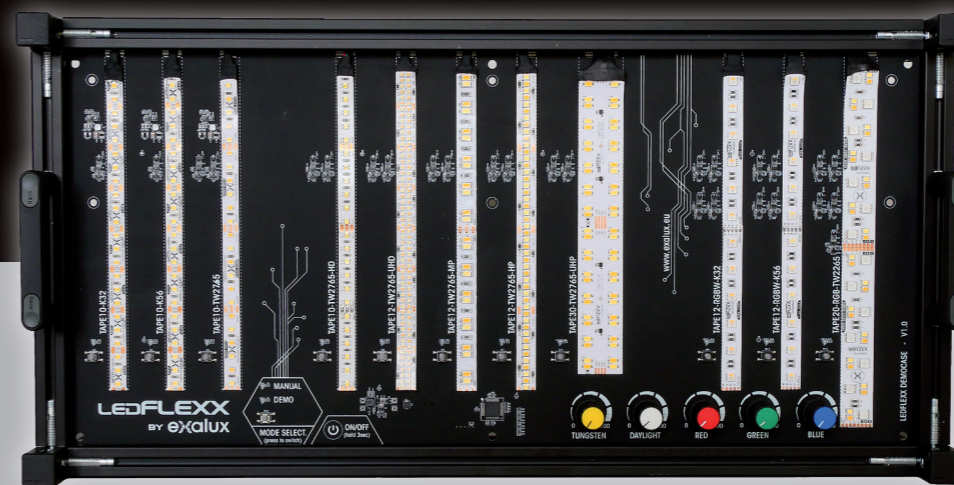

- Colour + White collection
- Embedded RGB WW dimmer
- Delivered with carrying case
- 24VDC Input

exalux

exalux.eu



EXALUX OFFICIAL DISTRIBUTOR



LIGHT



CONNECT



CONTROL



DIMMING

EXALUX, 1 rue de la Noë 44322 Nantes Cedex 3 France | +33 9 72 45 70 43 | contact@exalux.eu